

TRANSFORMER

Dr. A. Balamurugan

CONTENT

- ❑ What is transformer
- ❑ Structure and working principle
- ❑ Construction of transformer
- ❑ Losses in transformer
- ❑ Ideal v/s practical transformer
- ❑ Uses and application of transformer



INTRODUCTION

- A transformer is a device that changes ac electric power at one voltage level to ac electric power at another voltage level through the action of a magnetic field.
- There are two or more stationary electric circuits that are coupled magnetically.
- It involves interchange of electric energy between two or more electric systems
- Transformers provide much needed capability of changing the voltage and current levels easily.
 - They are used to step-up generator voltage to an appropriate voltage level for power transfer.
 - Stepping down the transmission voltage at various levels for distribution and power utilization.



WHAT IS TRANSFORMER

- A transformer is a static piece of apparatus by means of which an electrical power is transferred from one alternating current circuit to another electrical circuit
- There is no electrical contact between them
- The desire change in voltage or current without any change in frequency
- Symbolically the transformer denoted as

NOTE :

It works on the principle of mutual induction



www.EdisonTechCenter.org

**First transformer by
Ottó Bláthy, Miksa Déry, & Károly Zipernowsky
Budapest 1885**

Displayed at the Deutsches Museum, Munich, Germany

STRUCTURE OF TRANSFORMER

- The transformer two inductive coils ,these are electrical separated but linked through a common magnetic current circuit
- These two coils have a high mutual induction
- One of the two coils is connected of alternating voltage .this coil in which electrical energy is fed with the help of source called primary winding (P) shown in fig.
- The other winding is connected to a load the electrical energy is transformed to this winding drawn out to the load .this winding is called secondary winding(S) shown in fig.



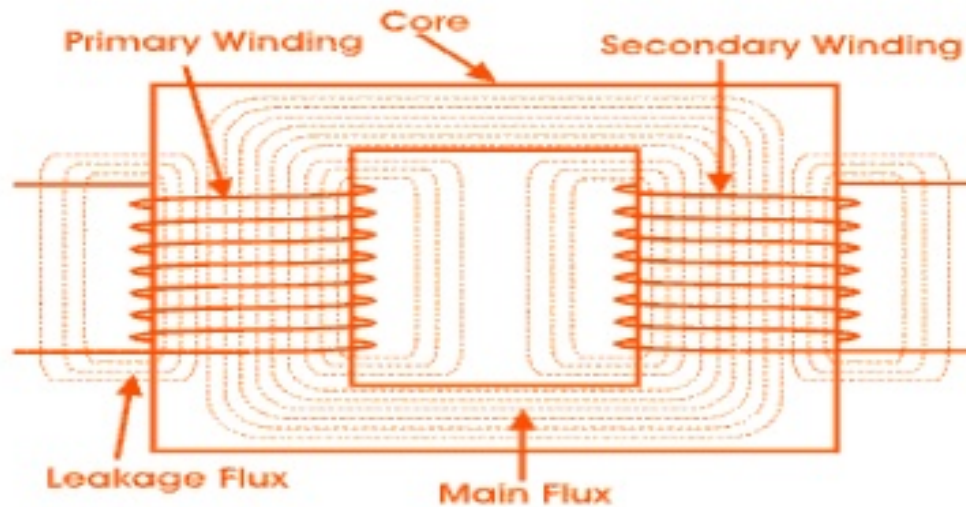

- The primary and secondary coil wound on a ferromagnetic metal core
- The function of the core is to transfer the changing magnetic flux from the primary coil to the secondary coil
- The primary has N_1 no of turns and the secondary has N_2 no of turns the of turns plays major important role in the function of transformer

WORKING PRINCIPLE

- The transformer works in the principle of mutual induction

“The principle of mutual induction states that when the two coils are inductively coupled and if the current in coil change uniformly then the e.m.f. induced in the other coils. This e.m.f can drive a current when a closed path is provide to it.”

- When the alternating current flows in the primary coils, a changing magnetic flux is generated around the primary coil.
- The changing magnetic flux is transferred to the secondary coil through the iron core
- The changing magnetic flux is cut by the secondary coil, hence induces an e.m.f in the secondary coil



e_p = primary voltage

e_s = secondary voltage

Φ = magnetic flux

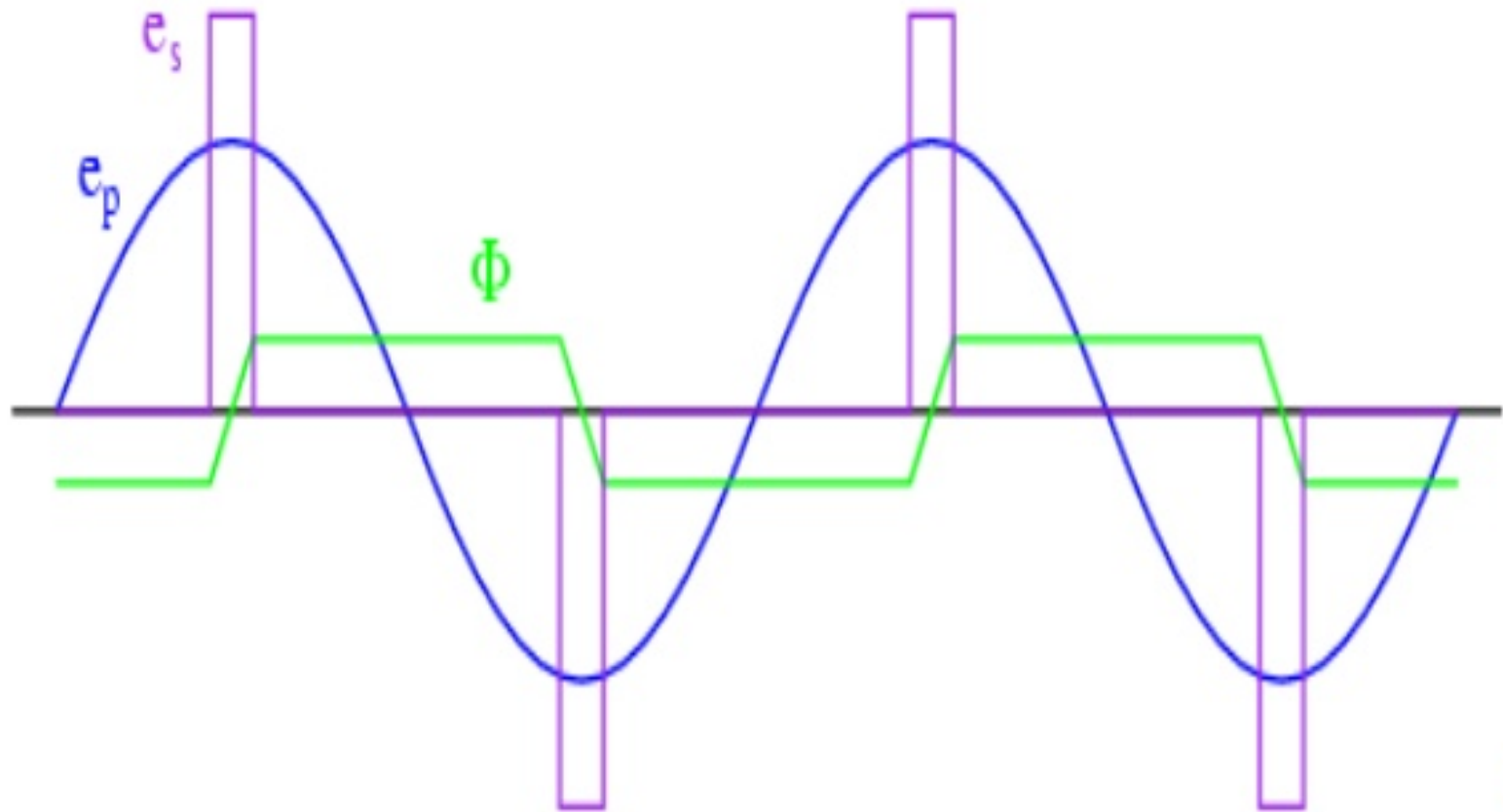

CONSTRUCTION OF TRANSFORMER

- These are two basic of transformer construction
- Magnetic core
- Windings or coils
- **Magnetic core**
- The core of transformer either square or rectangular type in size
- It is further divided into two parts vertical and horizontal
- The vertical portion on which coils are wound called limb while horizontal portion is called yoke. these parts are
- Core is made of laminated core type constructions, eddy current losses get minimize.
- Generally high grade silicon steel laminations (0.3 to 0.5mm) are used

WINDING

- Conducting material is used in the winding of the transformer
- The coils are used are wound on the limbs and insulated from each other
- The two different windings are wounds on two different limbs
- The leakage flux increases which affects the performance and efficiency of transformer
- To reduce the leakage flux it is necessary that the windings should be very close to each other to have high mutual induction

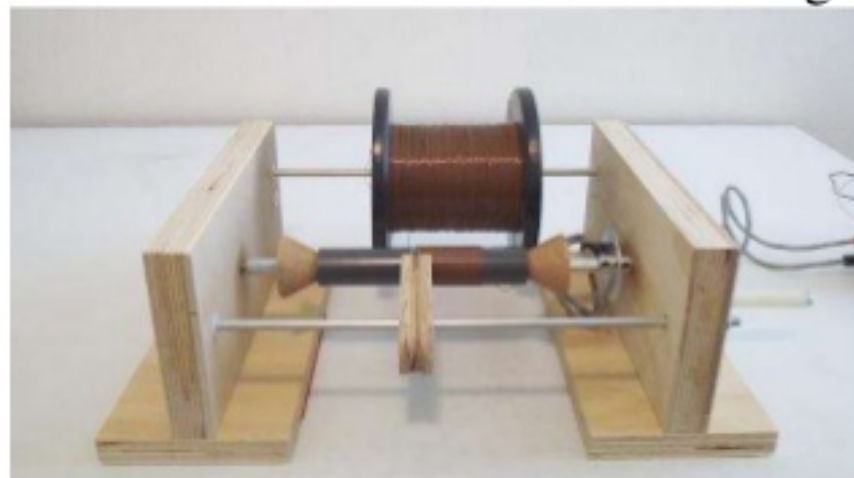

CORE TYPE CONSTRUCTION

- In this one magnetic circuit and cylindrical coils are used
- Normally L and T shaped laminations are used
- Commonly primary winding would on one limb while secondary on the other but performance will be reduce
- To get high performance it is necessary that other the two winding should be very close to each other

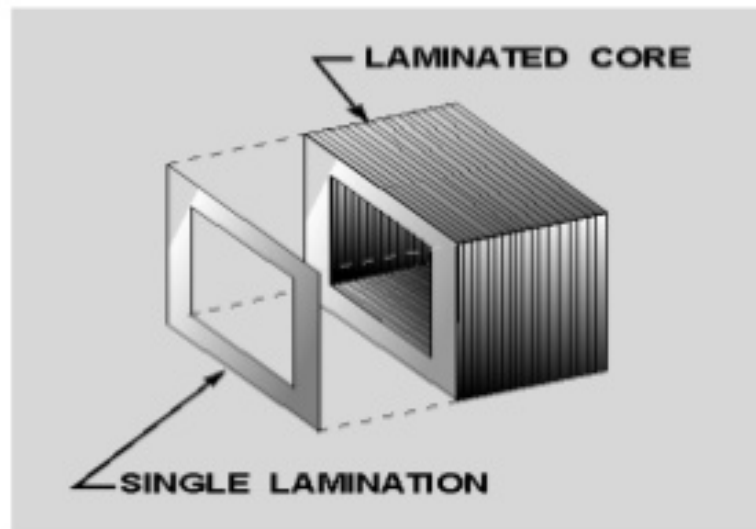

Shell-type Laminations

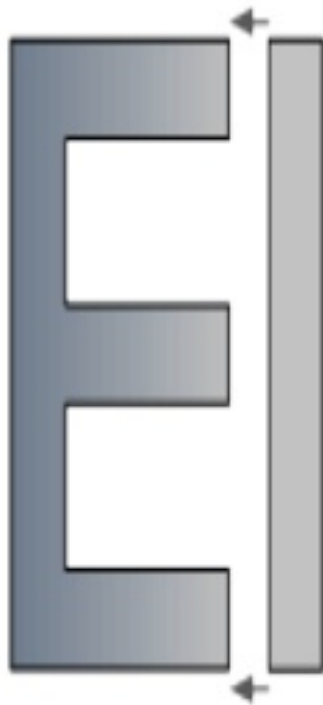

"E-I" Laminations

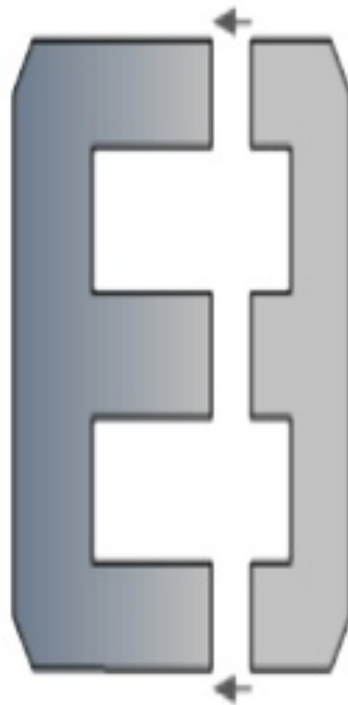

"E-E" Laminations

Core-type Laminations

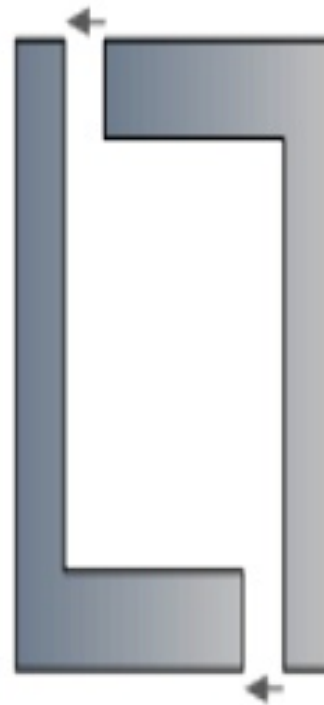

"L" Laminations

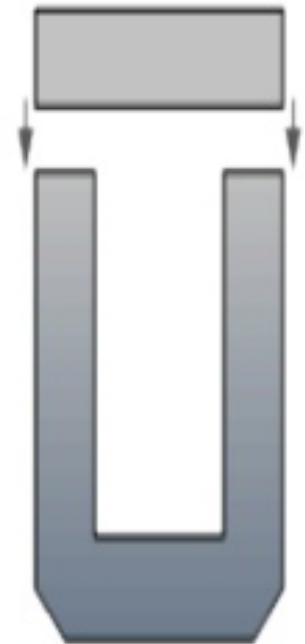

"U-I" Laminations



SHELL TYPE CONSTRUCTION

- In this type two magnetic circuit are used
- The winding is wound on central limbs
- For the cell type each high voltage winding lie between two voltage portion sandwiching the high voltage winding
- Sub division of windings reduces the leakage flux
- Greater the number of sub division lesser the reactance
- This type of construction is used for high voltage



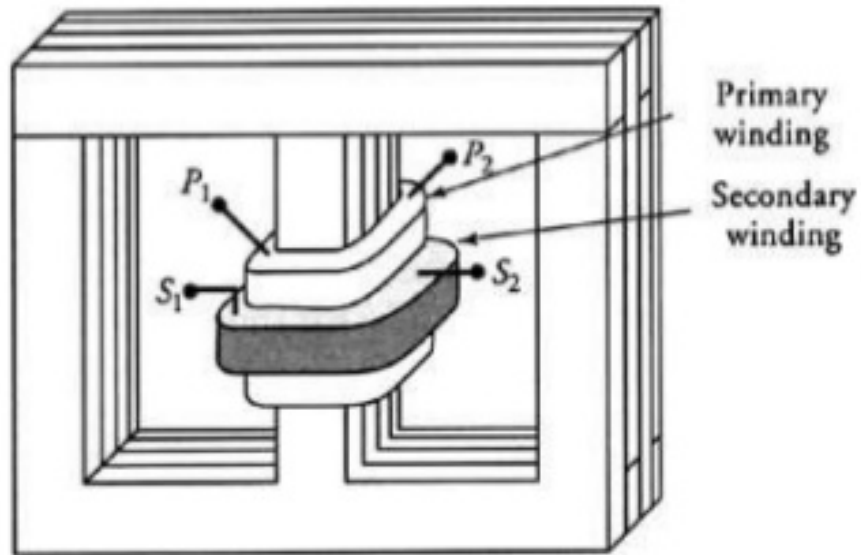

Core Type Transformer Cruciform Section

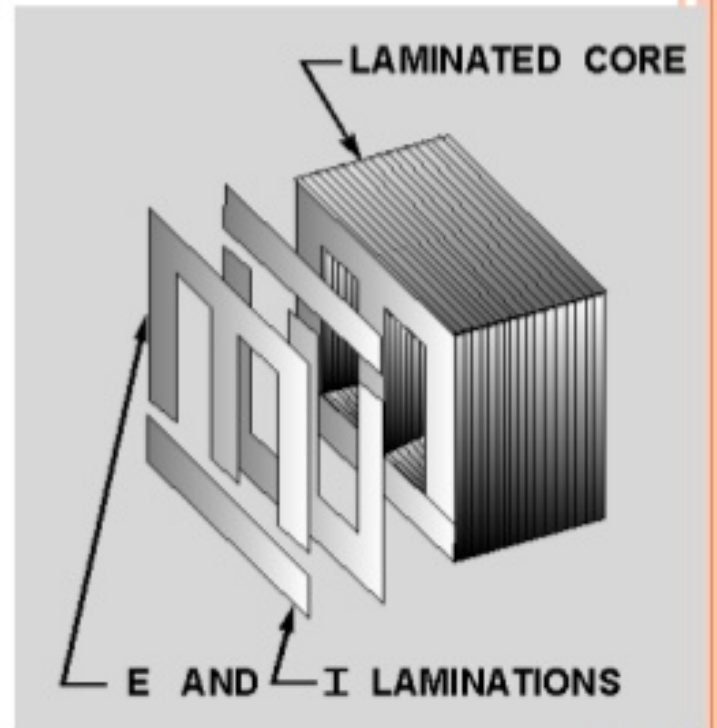
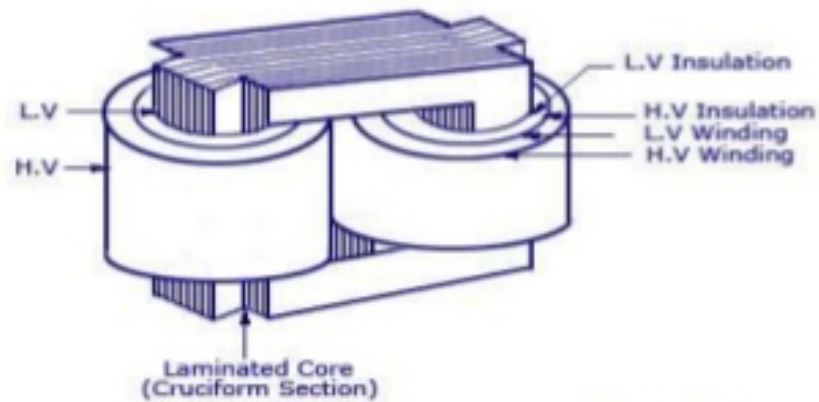

LOSSES IN TRANSFORMER

○ Copper losses :

It is due to power wasted in the form of I^2R due to resistance of primary and secondary. The magnitude of copper losses depend upon the current flowing through these coils.

The iron losses depend on the supply voltage while the copper depend on the current .the losses are not dependent on the phase angle between current and voltage .hence the rating of the transformer is expressed as a product o f voltage and current called VA rating of transformer. It is not expressed in watts or kilowatts. Most of the timer, is rating is expressed in KVA.



Hysteresis loss :

During magnetization and demagnetization ,due to hysteresis effect some energy losses in the core called hysteresis loss

Eddy current loss :

The leakage magnetic flux generates the E.M.F in the core produces current is called of eddy current loss.

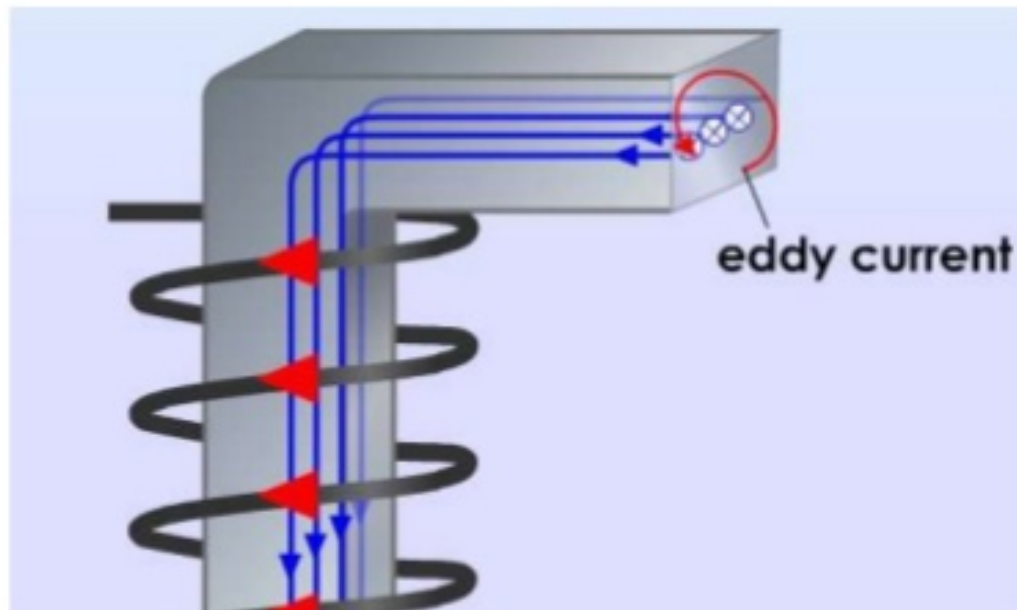

IDEAL V/S PRACTICAL TRANSFORMER

- A transformer is said to be ideal if it satisfies the following properties, but no transformer is ideal in practice.
- It has no losses
- Windings resistance are zero
- There is no flux leakage
- Small current is required to produce the magnetic field

While the practical transformer has windings resistance , some leakage flux and has lit bit losses



APPLICATION AND USES

- The transformer used in television and photocopy machines
- The transmission and distribution of alternating power is possible by transformer
- Simple camera flash uses fly back transformer
- Signal and audio transformer are used couple in amplifier

Today's transformer is become an essential part of electrical engineering



REFERENCE

- Electrical engineering by UA Bakshi
- Principal of electrical machine by VK Mehta
- Electrical machine by RK Rajput
- www.allaboutcircuit.com
- www.iiee.com



Thank you

Dr. A. Balamurugan

bala.snr@gmail.com